



Simple. Rugged. Reliable.

- Unique single "Rod" probe design
- Insertion length from 7.37" to 19'
- Strong stainless steel construction
- Detects extremely light, fluffy materials
- No calibration required
- Three sensitivity adjustments
- Wear and maintenance-free
- Auto sensing power supply
- Switch selectable high/low fail-safe
- High temperature units available
- Remote electronics available
- Suitable for high & low level indication, or plugged chute detection

VIBRATING ROD **Vibrating Level Sensors**

BINMASTER

www.binmaster.com

Vibrating Rod

Introduction

Description

The Vibrating Rod is a piezoelectric driven vibration type level switch that detects high, mid and low level in bins, silos, and hoppers filled with powders or dry bulk solid materials.

High performance and reliability

- The single rod design with its sharp edged vibrating blade prevents bridging of material typically associated with the "tuning fork" design. The sword shaped blade also lets material easily flow by, and thus prevents material build-up.



- Material sticking on the vessel wall has no influence on the function of the Vibrating Rod. All Vibrating Rod sensors are tip sensitive, allowing them to overlook side wall build-up.
- No false alarms due to rat-holing around the active sensor. The Vibrating Rod is driven with very low energy and will not dig a hole and cause false alarms.
- Fine tuning the vibrating system enables the instruments to reliably detect extremely light material with densities down to 1.25 lb./cu. ft.

Not affected by material characteristics

The Vibrating Rod principle of operation overcomes difficulties associated with changes in dielectric constant, humidity, temperature, and material density. There are 3 sensitivity settings selected by a sensitivity switch on the sensor board:

- Position A: High sensitivity for light and fluffy materials
- Position B: Medium Sensitivity
- Position C: Low sensitivity for materials that may form a deposit on the rod and heavier materials

Single blade design eliminates bridging

Applications

- Salt
- Flour
- Spices
- Pellets
- Animal Foods
- Carbon Black
- Chemicals
- Foundry Sands
- Powdered Milk
- Beans
- Sugar
- Coffee Beans
- Peanuts
- Tobacco
- Grain
- Wood Shavings
- Chalk
- Paper Products
- Styrofoam
- Cellulose
- Glass
- Granulars
- Clays
- Polystyrene
- Gravel
- Sawdust
- Coal

Principle of operation

The BinMaster Vibrating Level Sensors are piezoelectric devices with a single rod shaped vibrating element. The rod of the sensor vibrates if there is no material covering the active rod. When the rod is covered with material, the vibration is dampened and an electronic circuit forces a relay to switch. When the rod gets uncovered, the vibration will restart and the relay will switch back. The rod is fixed at two points in a way that it forms a perfect swinging-system with very low mechanical losses (also called transversal vibration). If you hit the end of the rod, it will vibrate on its resonance frequency and ring like a tuning fork. In action, the vibration is driven by a piezo system, which gets electrical pulses from the electronics. These electric pulses enlarge the size of the piezos which leads to a bowing of the rod. Since the pulses are exactly on the frequency where the rod is in resonance, the whole rod starts swinging. A second piezo system works as a swinging detector. If the piezo gets distorted, it gives a voltage signal to the electronics. This way, the electronics can check if the rod is vibrating or not.



Detects extremely light and fluffy materials

Vibrating Rod Advantages

Mounting Flexibility, Various Configurations



VR-41 & VR-51 Extended Vibrating Rods

These two Vibrating Rods have been designed to allow extended insertion lengths of up to 19'. These configurations are intended for top mount applications. The VR-41 uses a rigid 1" pipe extension made with galvanized or stainless steel available in lengths up to 13'. The VR-51 uses a steel rope reinforced cable and allows insertion lengths of up to 19'. Both of these units are factory sized to customer specifications.

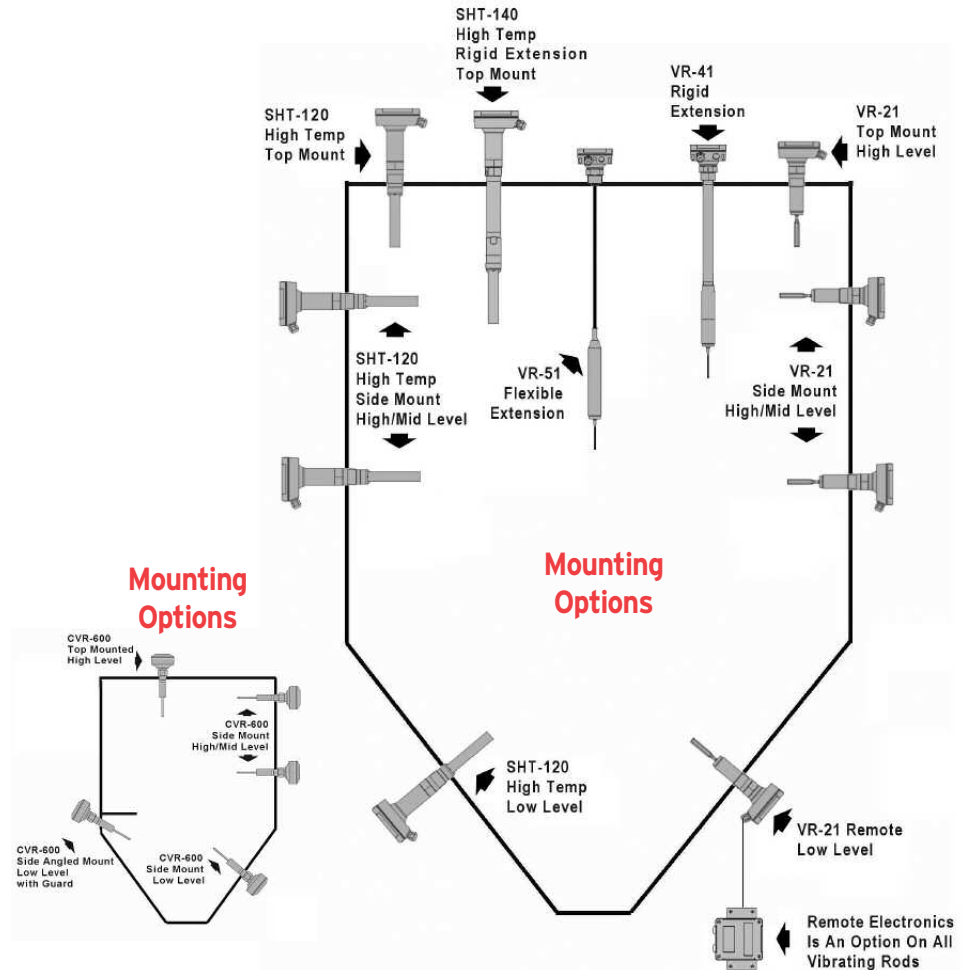

VR-21 Standard Vibrating Rod

The VR-21 is our standard model and has an insertion length of approximately 7". This model is suitable for both top and side mount applications. It mounts to the vessel with a 1 1/2" mounting socket.



CVR-600 Mini Vibrating Rod

The CVR-600 Compact Vibrating Rod is an economical, single rod, compact point level control that has been designed for use in small bins and hoppers. The small yet rugged design allows you to use the CVR-600 where other level sensors simply won't fit. Overall insertion length is 6".



SHT-120 & 140 High Temperature Vibrating Rod

The SHT-Series has been built specifically for higher process temperatures up to 482°F (250°C). The SHT-120 has a standard insertion length of 7.24". The SHT-140 can be extended into a vessel from 13" to 13' with a rigid pipe extension.

CVR Series Specification

Input Voltage: Wide range 20 - 250V AC/DC
Power Consumption: 3VA
Relay: SPDT 5A 250 VAC (option: DPDT)
Time Delay: 1 second from stop of vibration
 2 to 5 seconds for start of vibration
Temperature Range:
 • Ambient for electronic: -4°F to +140°F
 • Process Temp: -4°F to +300°F
Min. Material Density: From 3.5 lbs./cu. ft.
Max. Granular Size: 1 1/2"
Max. Pressure: 145 psi
Conduit Entry: 1/2"
Mounting: 1" NPT
Enclosure: Die cast aluminum NEMA 4X
Rod: AISI 304 Stainless Steel

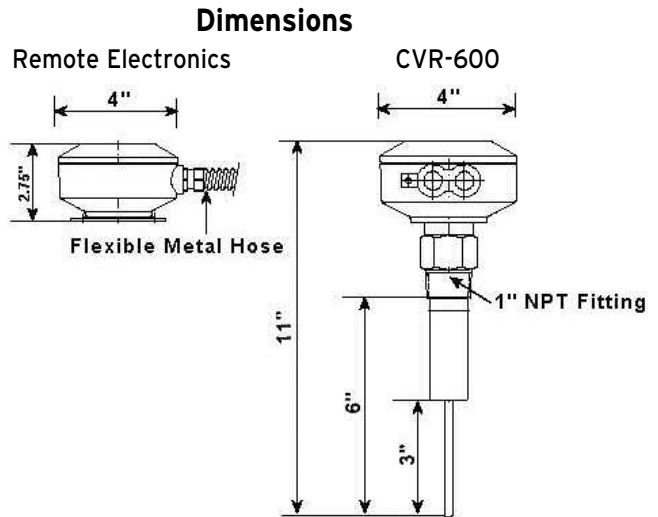

SHT Series Specifications

Input Voltage: Wide range 20 - 250V AC/DC
Power Consumption: 3VA
Relay: SPDT 5A 250 VAC (option: DPDT)
Time Delay: 1 second from stop of vibration
 2 to 5 seconds for start of vibration
Temperature Range:
 • Ambient for electronic: -4°F to +140°F
 • Process Temp: -4°F to +482°F
Min. Material Density: From 1.25 lbs./cu. ft.
Max. Granular Size: 1 1/2"
Max. Pressure: 145 psi
Conduit Entry: 1/2"
Mounting: 1 1/2" NPT
Enclosure: Diecast aluminum NEMA 4X
Rod: AISI 304 Stainless Steel

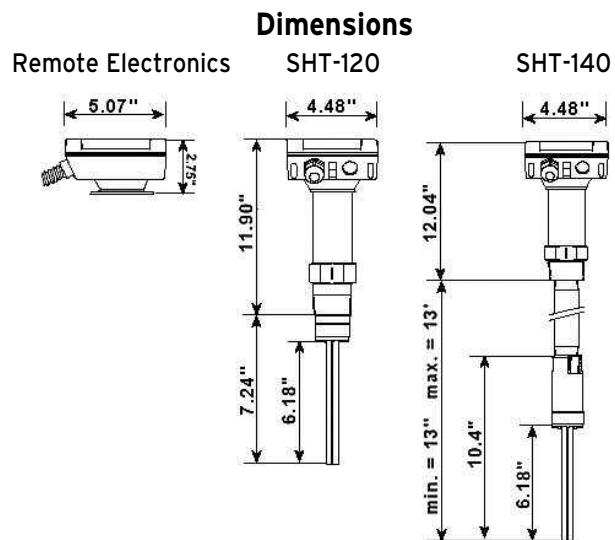

VR Series Specifications

Input Voltage: Wide range 20 - 250V AC/DC
Power Consumption: 3VA
Relay: SPDT 5A 250 VAC (option: DPDT)
Time Delay: 1 second from stop of vibration
 2 to 5 seconds for start of vibration
Temperature Range:
 • Ambient for electronic: -4°F to +140°F
 • Process Temp: -4°F to +176°F
Min. Material Density: From 1.25 lbs./cu. ft.
Max. Granular Size: 1 1/2"
Max. Pressure: 145 psi
Conduit Entry: 1/2"
Mounting: 1 1/2" NPT
Enclosure: Diecast aluminum NEMA 4X
Rod: AISI 304 Stainless Steel

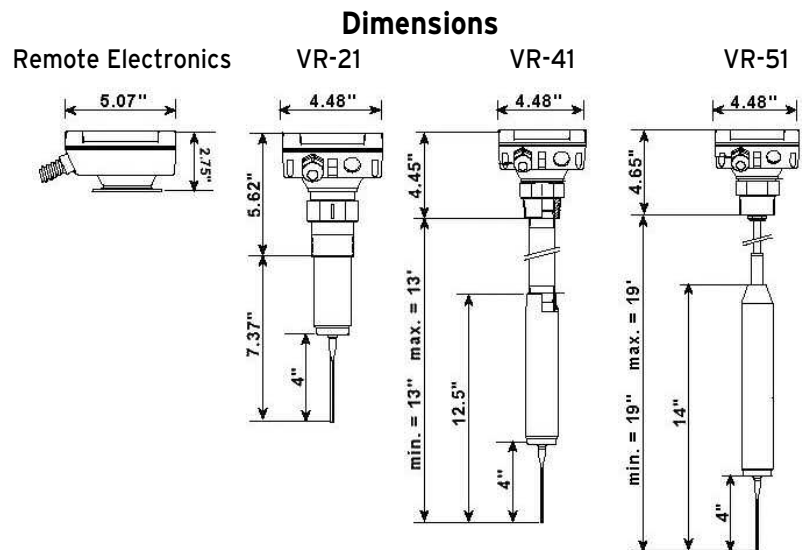

BINMASTER

Shipping Address: 7201 N. 98th St., Lincoln, NE 68507 / Mailing Address: P.O. Box 29709, Lincoln, NE 68529

Phone: 800-278-4241 or 402-434-9102 / Fax: 402-434-9133